

GMR 20/40

marine radar

installation guide



© Copyright 2004 Garmin Ltd. or its subsidiaries. All Rights Reserved

Garmin International, Inc.
1200 E 151st Street, Olathe, Kansas 66062
U.S.A.
Tel. 913/397.8200
Fax. 913/397.8282

Garmin (Europe) Ltd.
Unit 5, The Quadrangle, Abbey
Park Industrial Estate, Romsey,
SO51 9AQ U.K.
Tel. 44/0870.8501241
Fax. 44/0870.8501251

Garmin Corporation
No. 68, Jangshu 2nd Road, Shijr, Taipei
County, Taiwan
Tel. 886/2.2642.9199
Fax. 886/2.2642.9099

Except as expressly provided herein, no part of this manual may be reproduced, copied, transmitted, disseminated, downloaded or stored in any storage medium, for any purpose without the express prior written consent of Garmin. Garmin hereby grants permission to download a single copy of this manual and of any revision to this manual onto a hard drive or other electronic storage medium to be viewed and to print one copy of this manual or of any revision hereto, provided that such electronic or printed copy of this manual or revision must contain the complete text of this copyright notice and provided further that any unauthorized commercial distribution of this manual or any revision hereto is strictly prohibited.

Information in this document is subject to change without notice. Garmin reserves the right to change or improve its products and to make changes in the content without obligation to notify any person or organization of such changes or improvements.

Web site address: www.garmin.com

GARMIN® is a registered trademarks of Garmin Ltd. or its subsidiaries and may not be used without the express permission of Garmin.

WELCOME

Thank you for choosing the Garmin GMR 20/40. The GMR 20/40 utilizes the performance of Garmin radar and provides overlay and color information when combined with a marine Multi-Function Display (MFD).

Contact Garmin

If you should encounter any difficulty while using your GMR 20/40, or if you have any questions, in the U.S.A. contact Garmin Product Support by phone: 913/397-8200 or 800/800-1020, Monday thru Friday, 8 am to 5 pm Central Time; or by e-mail at sales@garmin.com. In Europe, contact Garmin (Europe) Ltd. at 44/0870.8501241.

Product Support Registration

Help us better support you by completing our on-line registration today! Have the serial number of your GMR 20/40 handy and connect to our Web site (www.garmin.com). Look for the Product Registration link on the Home page. Also, be sure to record your serial number in the area provided on this page.

Serial Number

Use this area to record the serial number in case it is lost, stolen, needs service, or if you need to contact Product Support. The 8-digit number is located on the bottom of the unit and on the outside of the product box. It is advisable to record this number prior to installation of the scanner. Be sure to keep your original sales receipt in a safe place or attach a photocopy inside the manual.

--	--	--	--	--	--	--	--

Serial Number:



NOTE: *The Garmin GMR 20/40 has no user-serviceable parts. Should you ever encounter a problem with your unit, please take it to an authorized Garmin NMEA dealer or contact Garmin Customer Service for repairs.*

Packing List

Before installing and getting started with your unit, please check to see that your package includes the following items. **If any parts are missing, please contact your Garmin dealer immediately.**

Standard Package:

- GMR 20 or 40 Radar Unit
- Power/Marine Network Cable
- Installation Manual
- Mount Kit Hardware
- Grommet for Marine Cable

Scanner Installation

The following section covers the installation and setup of the GMR 20 (2 kW) and GMR 40 (4 kW) Marine Radars. The GMR 20 and 40 only operate with components of the Garmin Marine Network with compatible MFD (Multi-Function Displays). See your Garmin dealer or the Garmin web site for more details. To complete the installation, you will need the appropriate fasteners, tools, and mounts. These items should be available at most marine dealers. Always wear safety goggles, ear protection, and a dust mask when drilling, cutting, or sanding. When drilling or cutting, always check first to see what is on the other side of the surface. When in doubt, seek professional assistance.

Installation Guidelines

In order to maximize the performance of the radar, please observe the following installation guidelines:

- An ideal scanner mounting location is high above the ship's keel line with a minimal part of the vessel's structure or rigging blocking the radar beam. Obstructions in the path of the radar beam may cause blind/shadow sectors or generate false echoes. The higher the installation position, the further the scanner can detect targets.
- Avoid mounting the scanner on the same level as smoke stacks or horizontal spreaders/crosstrees on a mast. Do not install the scanner near heat sources where it may be subjected to smoke or hot air from smoke stacks or heat from lights.
- The mounting surface/platform should be sturdy enough to support the weight of the scanner (26 lbs.), flat as possible, and parallel with the vessel's water line.
- It is recommended that the radar scanner is mounted out of range of personnel (horizontal beam width above head height). Do not look directly at the antenna at close range as your eyes are the most sensitive part of the body to electromagnetic energy. When properly installed and operated, the use of this radar will conform to the requirements of ANSI/IEEE C95.1-1992 Standard for Safety Levels with Respect to Human Exposure to Radio Frequency Electromagnetic Fields.

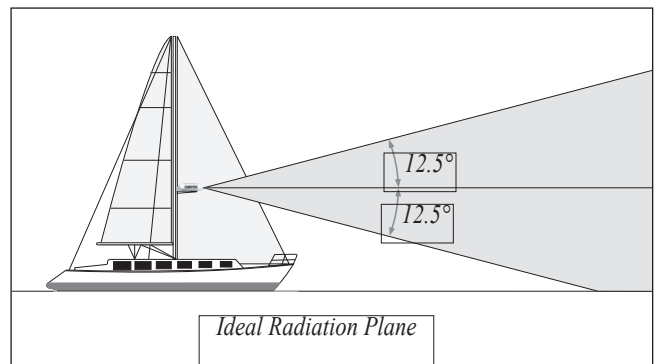
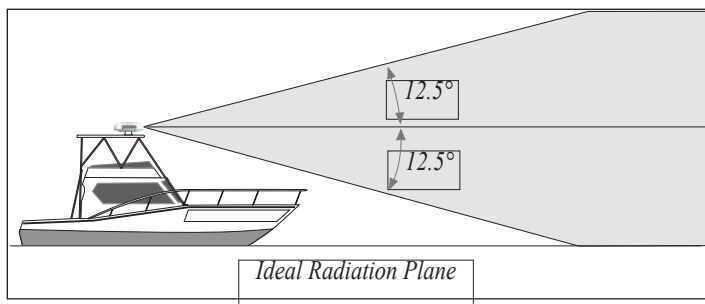

- Mount other electronics and cables more than 2 m (7 ft) from the path of a radar beam. A radar beam can normally be assumed to spread 25° vertically above and below the scanner's radiating element. For vessel's with higher bow angles at cruise speed, it may be helpful to lower the angle so the beam points slightly downwards to the waterline while at rest. Shims may be used as necessary.
- Install the scanner away from antennas for other electronics. GPS antennas should be either above or below the radar beam path of the scanner. Mount at least 1 m (3 ft) from any equipment transmitting or cables carrying radio signals e.g. VHF radios, cables and antennas. In the case of SSB radios, the distance should be increased to 2 m (7 ft). IEC 60936-1 clause 3-27.1 maximum distances from the antenna at which RF (Radio Frequency) levels can be expected.

GMR20 (100W/m squared = 40cm [15.75"]) (10W/m squared = 120cm [47.24"])

GMR40 (100W/m squared = 60cm [23.62"]) (10W/m squared = 175cm [68.90"])

- The radar scanner transmits electromagnetic energy. It is important that the radar is turned off and/or DC power input be disconnected whenever personnel are required to come close to the scanner to perform work on the scanner assembly or associated equipment.

Installation

The following order of mounting the scanner and attaching the Power/Network cables may vary depending on the installation location and mount used.

Mounting the Scanner

1. Once a suitable mounting location has been determined, verify that the mounting hole locations are aligned fore and aft, then drill four 9.5 mm (0.37") mounting holes referencing Figure 1 below. (This step is not necessary if you are using a pre-drilled Garmin compatible or Raymarine mount.)
2. Remove the supplied M8x30 bolts, flat washers, and spring washers (4 each) from the bottom of the scanner unit. Do NOT remove the outer case bolts. There are no user serviceable parts in the scanner and opening the case may void your warranty.
3. Align the notch and locking ring on the Power Cable to the power connector. Press the 2-pin Power Cable to the power connector and the RJ-45 Marine Network Cable to the RJ-45 socket (Figure 2). Turn the Power Cable locking ring clockwise until it stops. Tighten the RJ-45 locking ring clockwise until it is firmly sealed.
4. The Power/Network Cable may be pressed into one of the three guide grooves moulded into the bottom of the scanner case (Figure 2). Avoid excessive bending or twisting of the cable. See the following "Cable Runs" section for more information.
5. Position the scanner on the mounting surface with the triangular marks on the case aligned to the front of the vessel and the rounded marks aligned towards aft (Figure 2). A bead of marine sealant may be applied around each of the mounting holes on the mounting surface.
6. Fasten the scanner to the mounting surface using the M8x1.25x30 hex bolts, spring washers, and flat washer in the order show in Figure 3. The supplied M8x1.25x30 bolts, flat washers, and spring washers (4 each) may be used on mounting thicknesses of 5-10 mm (3/8") (recommended). For surfaces over 10 mm (3/8"), locally supplied longer bolts are needed. **The bolts should be torqued to between 13.7-18.6 N m (10-14 lbf ft).**

Cable Runs

Route the cable as needed, depending on the type of mount you are using. Do NOT cut the cable! It may be necessary to drill a 31.7 mm (1.25") hole for routing the Power/Network cable. Garmin provides a rubber Cable Grommet which may be used to cover the cable installation hole. The grommet does NOT provide a waterproof seal. You may choose to apply a marine sealant after installation to weatherproof around the grommet and cable. Additional Cable Grommets may be purchased through Garmin or your Garmin dealer.

When installing the Power/Network Cable, observe the following:

- To ensure safety, use the appropriate tie-wraps, fasteners, and sealant to secure the cable along a route and through any bulkhead or deck. Avoid running the cable near moving objects, high heat sources, or through doorways and bilges.
- Avoid installing the cable next to or in parallel other cables such as, radio antenna lines, power cables, etc. This is essential to avoid interference to/from other equipment. If this is not possible, shield the cable with metal conduit or a form of EMI shielding.
- Install the Power portion of the cable as close to the battery source as possible. A minimum on 10 v D.C. is required at the 15m cable connector during radar turn-on and operation. See table below for recommended wire gauge between radar cable and battery.

Up to:	
2 meters (6.5ft)	16 AWG
4 meters (13ft)	14 AWG
6 meters (19ft)	12 AWG

Wire Gauge Table

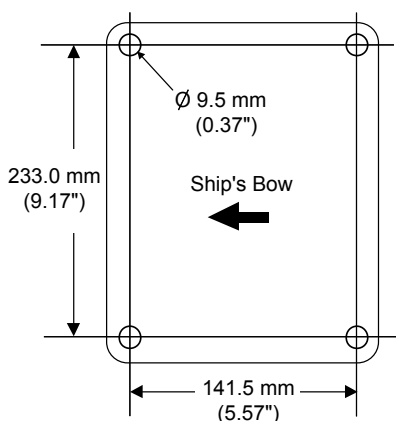

Figure 1

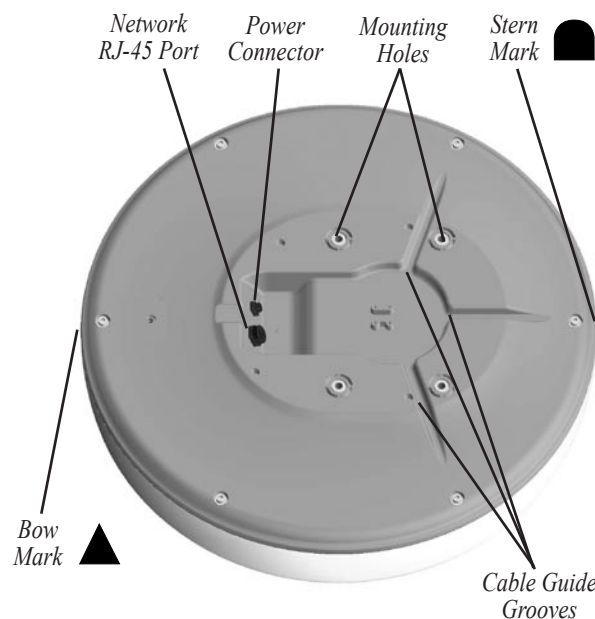

Figure 2

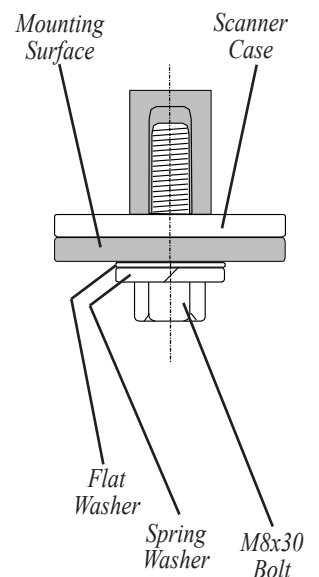
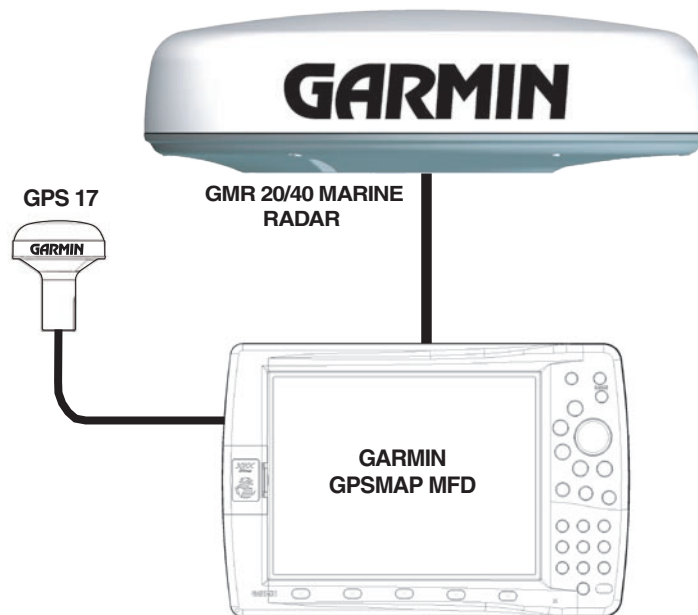

Figure 3

Final Wiring Connections

Once the scanner is installed and the cable routed, you are ready to connect the Power and Marine Network.

1. Connect the Black Ground (-) wire to the vessel's negative power terminal.
2. Connect the Power (+) wire (with fuse holder) to the vessel's positive power terminal.
3. For a stand-alone network (MFD and Radar only), attach the RJ-45 Marine Network Cable to the RJ-45 socket on the back of the MFD. For an expanded network (MFD, Radar, GMS 10, etc.) attach, the RJ-45 Marine Network Cable to an open RJ-45 socket on the GMS 10 Network Power Expander. Tighten the RJ-45 locking ring clockwise until it is firmly sealed.



Stand Alone Network

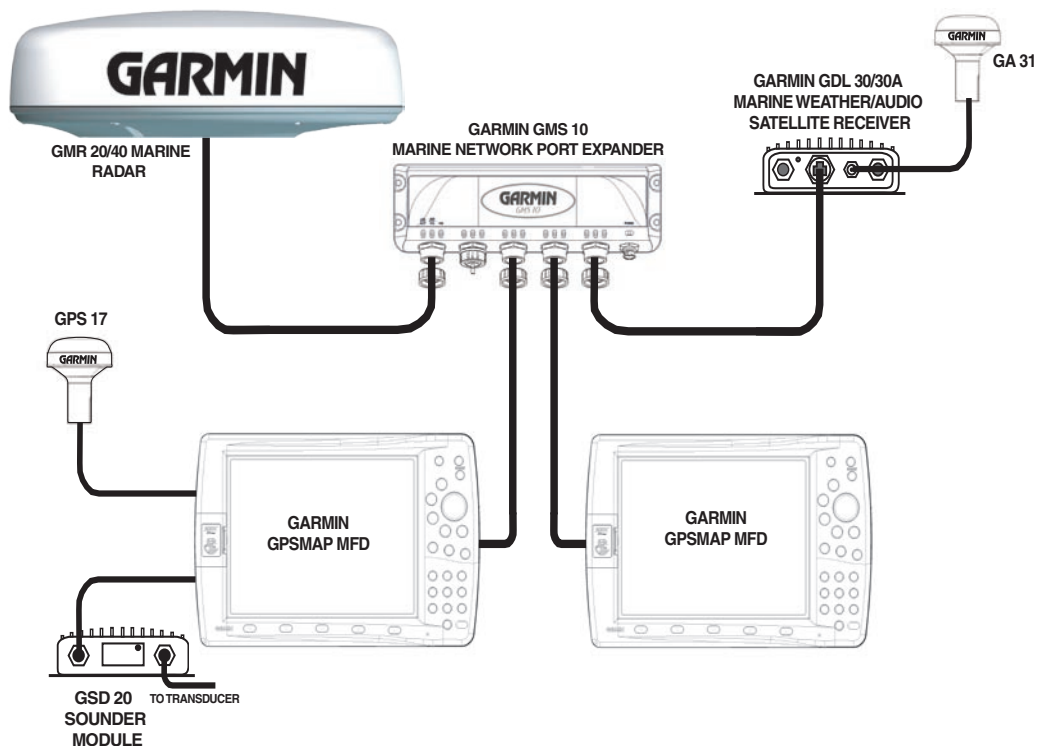

Expanded Network

Powering on the System

Once successfully installed the scanner is ready to be powered on.

1. On the MFD (Multi-Function Display), press the red Power button. This will automatically power on the scanner. The Welcome Page appears showing the GMR 20 or 40 as a detected Network Connection.
2. Press **ENTER** when "I Agree" turns yellow, then press **PAGE** until the Radar Page appears.
3. During Standby mode, a countdown appears on the Radar page (and on the top status bar) counting down as the scanner prepares to operate.
4. Once ready, hold **FCTN** until "Do you want to begin radar transmission?" appears and release.
5. When safe to do so (personnel clear of radar beam path), highlight 'Yes' and press **ENTER**. The scanner spins up and is now operating.

Bearing Offset

It may be necessary to adjust the bearing of the radar picture shown on the screen. First, using a magnetic compass, take an optical bearing of a stationary target located within viewable range. Measure the target bearing on the radar. If the bearing deviation is more than +/- 1°, then do the following to correct for the offset:

1. From the Radar Page, press the '**ADJ**' key to display the Adjustment Menu.
2. From the Adjustment Menu, select 'Setup' and press **ENTER**.
3. Using the **ARROW KEYPAD**, highlight the 'Front of Boat Offset' slider and press **ENTER**.
4. Press Left on the **ARROW KEYPAD** to adjust to a negative value or press Right to adjust to a positive value. The preview window below changes as you adjust the slider.
5. Once an offset has been determined, press **ENTER** to save and press **QUIT** to return back to the Radar Page. Your new Garmin Marine radar is now ready to use! Refer to the GMR 20/40 Owner's manual (190-00457-00) for details on operating the scanner.

Specifications

Unit Dimensions:	28" (710 mm) D x 8" (205 mm) H.
Radar Scanner Weight:	Unit 26 lbs; cable 8.35 lbs
Range Scales (Range Rings):	GMR 40 — 1/8nm (1/32nm) to 36nm (9nm) GMR 20 — 1/8nm (1/32nm) to 24nm (6nm)
Power Output:	GMR 20: 2 kW / GMR 40: 4kW
Power Input Source:	10-35 v D.C. 28W
Operating Temperature Range:	-25°C to 70°C, and a relative humidity up to 95% at 35°C
Beamwidth:	Horizontal beamwidth of 3.6° nominal / Vertical beamwidth of 25° nominal
Range:	GMR 20: 24 nm / GMR 40: 36 nm
Wind Velocity:	Wind speed up to 100 Kts
Antenna RPMs:	24 rpm
Range Ring Accuracy:	+/- 1 meter
Bearing Accuracy:	1°
Minimum Range:	35 meters
Range Discrimination:	30 meters
Sensitivity and Tune Controls:	Gain, Sea Clutter, Rain Clutter, Frequency Tune
Radar/Chart Synchronization:	Overlay mode. Split overlay with standard radar presentation.
Off Center Function:	Look ahead, Auto Shift, and Manual
RF Transmit Frequency:	9410 ± 30 MHz

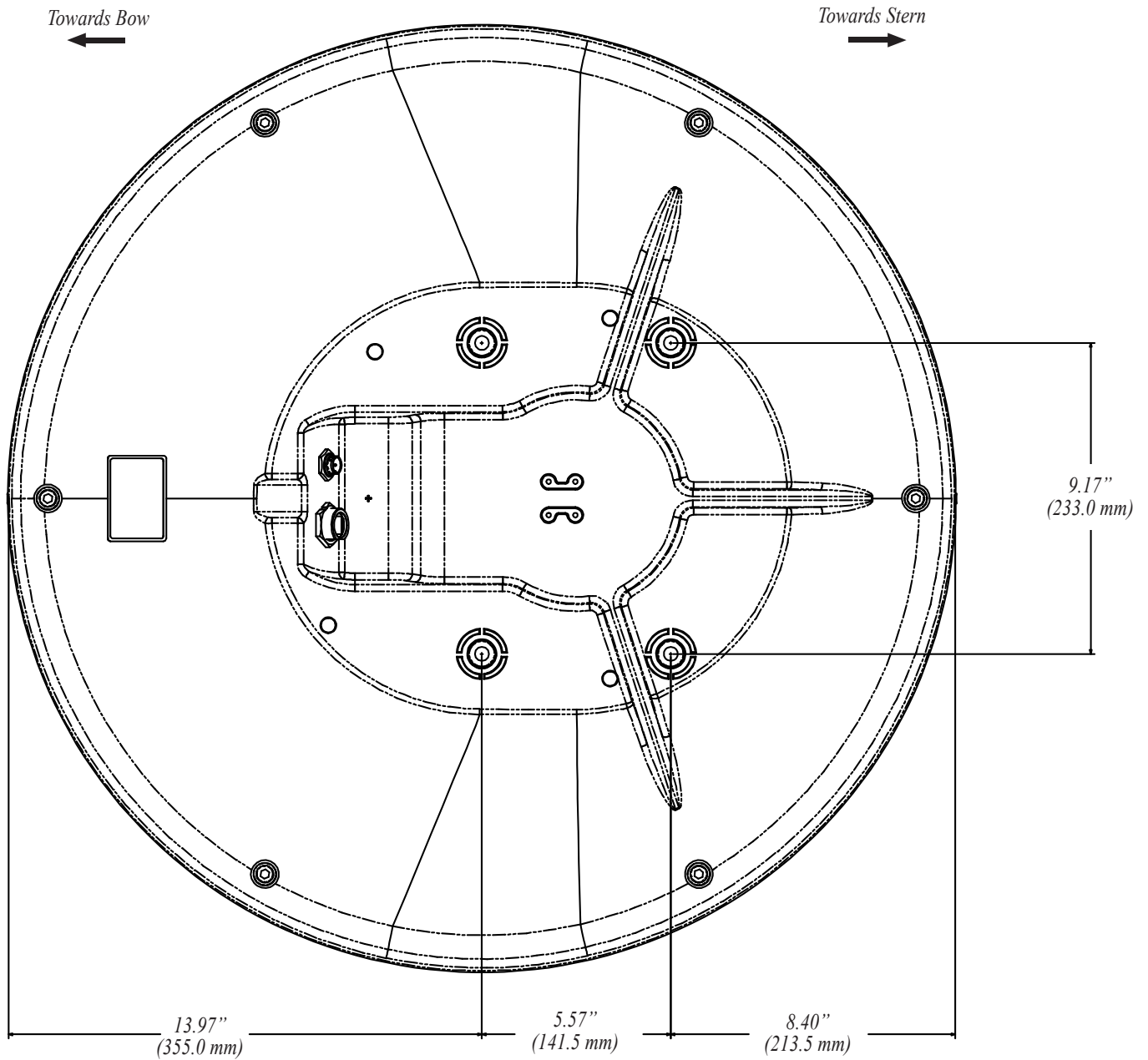
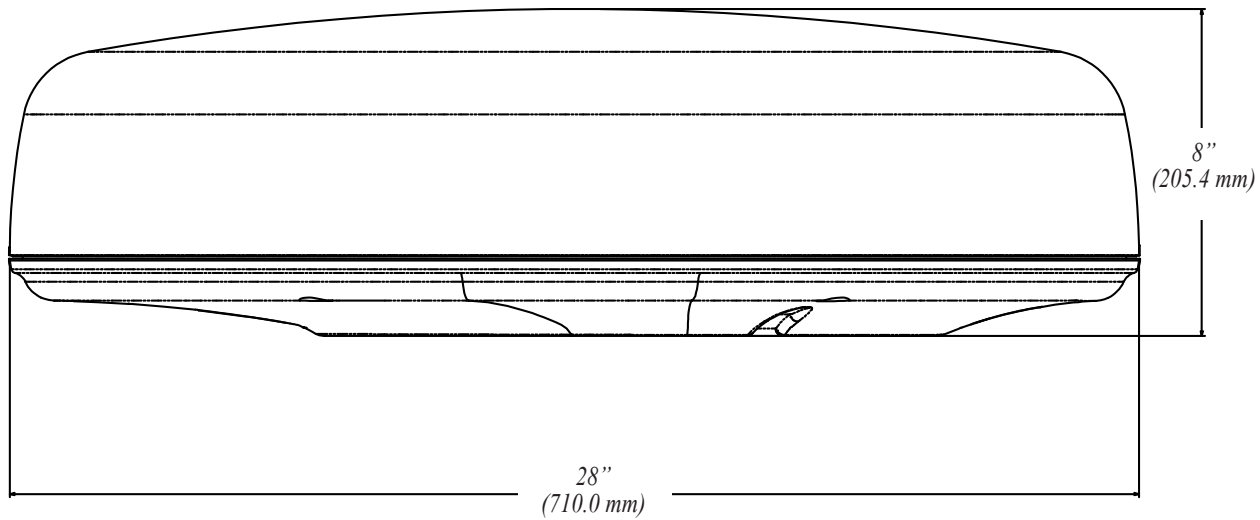



Warning and Cautions

CAUTION: Use the GMR 20/40 at your own risk. To reduce the risk of unsafe operation, carefully review and understand all aspects of this Owner's Manual, and thoroughly practice operation using the simulator mode prior to actual use. When in actual use, carefully compare indications from the GMR 20/40 to all available navigation sources, including the information from other NAVAIDs, visual sightings, charts, etc. For safety, always resolve any discrepancies before continuing navigation.

CAUTION: IT IS THE USER'S RESPONSIBILITY TO USE THIS PRODUCT PRUDENTLY. THIS PRODUCT IS INTENDED TO BE USED ONLY AS A NAVIGATIONAL AID AND MUST NOT BE USED FOR ANY PURPOSE REQUIRING PRECISE MEASUREMENT OF DIRECTION, DISTANCE, LOCATION, OR TOPOGRAPHY.

WARNING: This product, its packaging, and its components contain chemicals known to the State of California to cause cancer, birth defects, or reproductive harm. This Notice is being provided in accordance with California's Proposition 65. If you have any questions or would like additional information, please refer to our web site at <http://www.garmin.com/prop65>.

WARNING: The radar scanner transmits electromagnetic energy. Ensure that the scanner has been installed according to the recommendations given in this guide, and that all personnel are clear of the scanner, before switching to transmit mode.

FCC Compliance

The GMR 20/40 complies with Part 80 of the FCC rules. It has received a grant of equipment authorization, issued under the authority of the FCC.

This equipment generates, uses and can radiate radio frequency energy and, if not installed and used in accordance with the instructions, may cause harmful interference to radio communications. However, there is no guarantee that interference will not occur in a particular installation. If this equipment does cause harmful interference to radio or television reception, which can be determined by turning the equipment off and on, the user is encouraged to try to correct the interference by one of the following measures:

- Reorient or relocate the receiving antenna.
- Increase the separation between the equipment and the receiver.
- Connect the equipment into an outlet on a circuit different from that to which the receiver is connected.
- Consult the dealer or an experienced radio/TV technician for help.

Software License Agreement

BY USING THE GMR 20/40, YOU AGREE TO BE BOUND BY THE TERMS AND CONDITIONS OF THE FOLLOWING SOFTWARE LICENSE AGREEMENT. PLEASE READ THIS AGREEMENT CAREFULLY.

Garmin grants you a limited license to use the software embedded in this device (the “Software”) in binary executable form in the normal operation of the product. Title, ownership rights and intellectual property rights in and to the Software remain in Garmin.

You acknowledge that the Software is the property of Garmin and is protected under the United States of America copyright laws and international copyright treaties. You further acknowledge that the structure, organization and code of the Software are valuable trade secrets of Garmin and that the Software in source code form remains a valuable trade secret of Garmin. You agree not to decompile, disassemble, modify, reverse assemble, reverse engineer, or reduce to human readable form the Software or any part thereof or create any derivative works based on the Software. You agree not to export or re-export the Software to any country in violation of the export control laws of the United States of America.

LIMITED WARRANTY

This Garmin product is warranted to be free from defects in materials or workmanship for one year from the date of purchase. Within this period, Garmin will at its sole option, repair or replace any components that fail in normal use. Such repairs or replacement will be made at no charge to the customer for parts or labor, provided that the customer shall be responsible for any transportation cost. This warranty does not cover failures due to abuse, misuse, accident or unauthorized alteration or repairs.

THE WARRANTIES AND REMEDIES CONTAINED HEREIN ARE EXCLUSIVE AND IN LIEU OF ALL OTHER WARRANTIES EXPRESS OR IMPLIED OR STATUTORY, INCLUDING ANY LIABILITY ARISING UNDER ANY WARRANTY OF MERCHANTABILITY OR FITNESS FOR A PARTICULAR PURPOSE, STATUTORY OR OTHERWISE. THIS WARRANTY GIVES YOU SPECIFIC LEGAL RIGHTS, WHICH MAY VARY FROM STATE TO STATE.

IN NO EVENT SHALL GARMIN BE LIABLE FOR ANY INCIDENTAL, SPECIAL, INDIRECT OR CONSEQUENTIAL DAMAGES, WHETHER RESULTING FROM THE USE, MISUSE, OR INABILITY TO USE THIS PRODUCT OR FROM DEFECTS IN THE PRODUCT. Some states do not allow the exclusion of incidental or consequential damages, so the above limitations may not apply to you.

Garmin retains the exclusive right to repair or replace the unit or software or offer a full refund of the purchase price at its sole discretion. SUCH REMEDY SHALL BE YOUR SOLE AND EXCLUSIVE REMEDY FOR ANY BREACH OF WARRANTY.

To obtain warranty service, contact your local Garmin authorized dealer. Or call Garmin Product Support at one of the numbers shown below, for shipping instructions and an RMA tracking number. The unit should be securely packed with the tracking number clearly written on the outside of the package. The unit should then be sent, freight charges prepaid, to any Garmin warranty service station. A copy of the original sales receipt is required as the proof of purchase for warranty repairs.

Products sold through online auctions are not eligible for rebates or other special offers from Garmin. Online auction confirmations are not accepted for warranty verification. To obtain warranty service, an original or copy of the sales receipt from the original retailer is required. Garmin will not replace missing components from any package purchased through an online auction.



NOTE: *The GMR 20/40 does not contain any user-serviceable parts. Repairs should only be made by an authorized Garmin service center. Unauthorized repairs or modifications could result in permanent damage to the equipment, and void your warranty.*

Garmin International, Inc.
1200 East 151st Street
Olathe, Kansas 66062, U.S.A.
Phone: 913/397.8200
USA Only: 800/800.1020
FAX: 913/397.0836

Garmin (Europe) Ltd.
Unit 4, The Quadrangle, Abbey Park Industrial Estate
Romsey, SO51 9DL, U.K.
Phone: 44/0870.8501241
FAX: 44/0870.8501251
www.garmin.com

DECLARATION of CONFORMITY

Application of Council Directive: 1995/5/EC

Standard to which Conformity is Declared: EN 60945: 1997 Marine Navigational Equipment – General Requirements

Manufactured by: GARMIN International & GARMIN Corporation
Manufacture's Address: 1200 E. 151st Street No.68, Jangshu 2nd Rd.,
Olathe, Kansas 66062 Shijr, Taipei County,
U.S.A TAIWAN, R.O.C.

Authorised Representative: GARMIN (Europe) Ltd, The Quadrangle,
Abbey Park Ind. Estate, Romsey, Hampshire,
SO51 9DL, U.K.

Type of Equipment: Marine Radar

Model Number(s): GMR20/40

The undersigned does hereby declare that the equipment complies to the above Directives

Paul Morrow
Quality Manager
GARMIN (Europe) Ltd



Date: 19th April 2004

SAMPLE DOC



© Copyright 2004 Garmin Ltd. or its subsidiaries

Garmin International, Inc.
1200 E 151st Street, Olathe, Kansas 66062 U.S.A.
Tel. 913/397.8200
Fax. 913/397.8282

Garmin (Europe) Ltd.
Unit 5, The Quadrangle, Abbey Park Industrial Estate, Romsey, SO51 9AQ U.K.
Tel. 44/0870.8501241
Fax. 44/0870.8501251

Garmin Corporation
No. 68, Jangshu 2nd Road, Shijr, Taipei County, Taiwan
Tel. 886/2.2642.9199
Fax. 886/2.2642.9099

Part Number 190-00457-02 Rev. A